

SPECIFICATION MECHANICAL

1. Housing Material: Polycarbonate, UL 94V-2. NO Poison
UL 94V-0. NO Poison
2. Material Contact: Brass / Phosphor Bronze.
3. Gold Plating: FU" 2-3U" 3U" 6U" 15U" 30U" 50U"
4. Contact area plated Nickel over 60u",
the other area plated Nickel over 30u".
5. Housing Color: Transparence.
6. Operation Temperature: -40°c to 70°c.

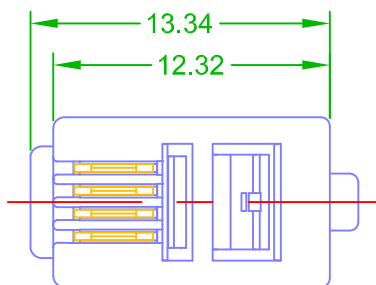
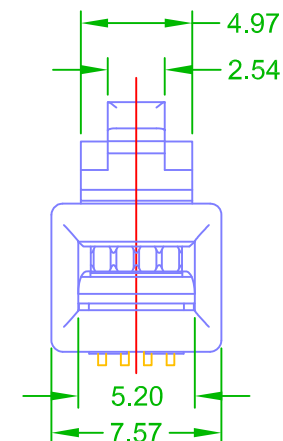
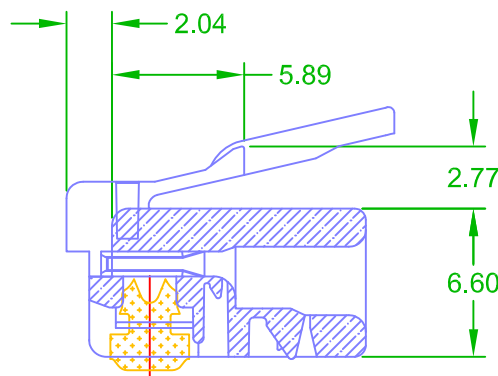
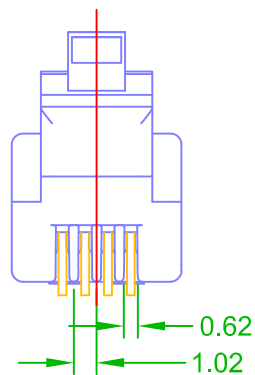
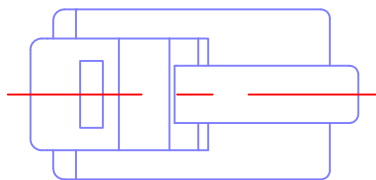

NOTE TOL: ±0.1

A	2004/11/11				
/REV	日期/DATE	説明/DESCRIPTION			
UNIT	m/m	DRAWING		DATE	2004/11/11
SCALE	1/1	CHECKED		DATE	
3RD	⊕ ⊖	APPROVED		DATE	
			Item	4P4C	
			Description	F	
			Part No	9105-44	

