

20000±50mm

Cable Marking: HIGH SPEED HDMI® CABLE WITH ETHERNET E505789 兄 AWM STYLE 20276 80°C 30V VW-1

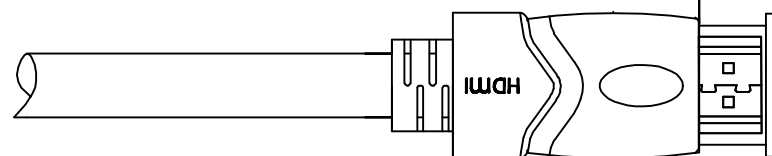
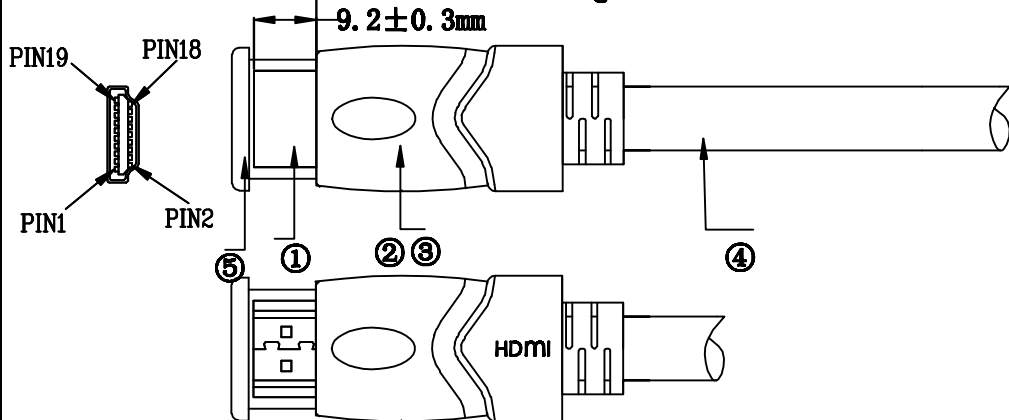

**Electronic testing:**

1. Voltage rating: 30V
2. Temperature rating: 80°C
3. Spark test: AC- 1500V/In the air
4. Dielectric strength: AC-500V/1 sec MIN
5. Insulation resistance: FOAM-PE-SKIN/PE DC-500V 100MΩ .KM MIN. at 20°C
6. Conductor resistance. 30AWG-376 Ω/KM MAX at 20°C
7. (1P-5P) Impedance: 100±10Ω
8. Attenuation: at 0.3~825MHz<5dB/cable; at 0.825~2.475GHz<12dB/cable at 2.475~4.125GHz<20dB/cable at 4.125~5.100GHz<25dB/cable
9. Time Delay Skew: within a pair: ≦1.78ns/cable between pairs: ≦1.78ns/cable
10. HEAC: Attenuation: at 0.3~1MHz<0.5dB/cable; at 1~10MHz<1.6dB/cable; at 10~100MHz<5dB/cable; at 100~200MHz<7.1dB/cable
12. HEAC: Time Delay Skew: within a pair: ≦112ps/cable

Drain wire: 1C/0.32±0.06mmBC

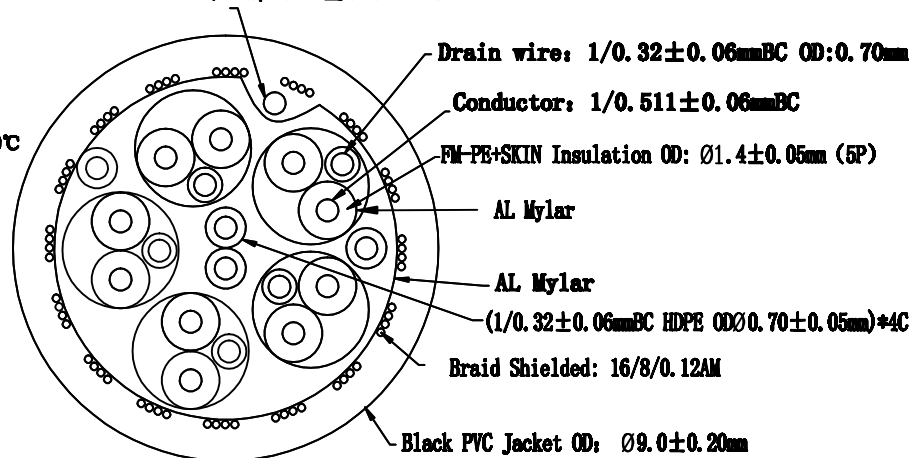

**CONNECTION**

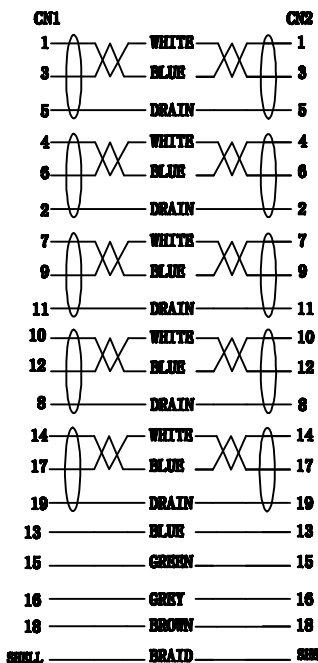

**Physics testing:**

1. Tensile strength test are before aging: JACKET: 1500PSI min Aged: 70% min
2. Elongation before aging: JACKET: 100% min Aged: 85% min
3. flame test of cable: VW-1
4. 100% short and open test

 SPECTRA CONNECTRONICS LLP APPROVED CHECKED DRAWING DESIGNED				No.	DESCRIPTION
				Yujian	Jack
				②	PVC BLACK 50P Connectors & Zinc alloy
				③	Dustcap: Transparent PVC
				④	UL20276 HDMI 1.4V (24#*1P+D+AL)*5P+28#*4C+AL+D+ALB OD:9.0MM COLOR:BLACK
				⑤	Protection Cap: PE Color For Transparent